

General Description

Series RE06*T (NG6) proportional pressure relief valves are direct operated proportional solenoid valves with integral control electronics.

The digital onboard electronic is situated in a robust metal housing and can be used in rough environments. The nominal values of the valves are factory set. Additionally the ProPxD software permits the editing of all parameters. The software is also used for the digital electronic modules. The cable for connection to a serial RS232 interface is available as accessory.

The electrical connection is available in 2 options:

Code F: 6 + PE central connection

+/- 10V command signal (preset)

+10V reference voltage output

Code R: 6 + PE central connection

4...20mA command signal (preset)

Function

When the pressure in port P or A exceeds the pressure setting at the solenoid, the cone opens to port T and limits the inlet pressure to the adjusted level.

The pressure adjustment is effected by applying current to the solenoid. The control signal is modulated to the solenoid current by the electronics.

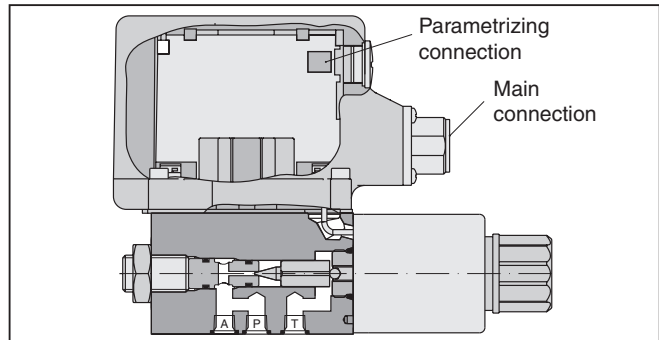
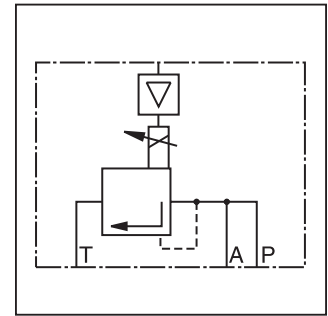

Features

- Direct operated pressure relief valve
- Onboard electronics
- Very low pressure adjustment of p_{min} .
- Subplate mounting acc. to ISO 6264
- 6 pressure ranges
- 2 pressure inlet ports, A and P

Ordering Information

RE	06	M	□	T	2	□	1	□	0	□
Proportional Pressure Relief Valve	Size	Manifold Mounting	Pressure Range	Integrated Electronics	Configuration	Seal	Valve Open at Zero Command	Electronic Variations	Electronic Option	Design Series
	Code Description				Code Description			Code Description		NOTE: Not required when ordering.
	06 NG6 D03, CETOP 3				N Nitrile V Fluorocarbon			Voltage input F 0...+10V with reference output +10V R Current input 4...20mA		
			Code Description							
			05 50 Bar (725 PSI) 10 105 Bar (1523 PSI) 17 175 Bar (2538 PSI) 21 210 Bar (3045 PSI) 25 250 Bar (3625 PSI) 35 350 Bar (5075 PSI)							

Weight: NG6 2.2 kg (4.9 lbs.)

Bolt Kit	Qty	Size
BK375	4	M5x30mm
BK209	4	10-24x1.25

Please order plugs separately. See Accessories.

Parametrizing cable OBE => RS232
 Item no. 40982923

WARNING: This product can expose you to chemicals including Lead, Nickel (Metallic), or 1,3-Butadiene which are known to the State of California to cause cancer, and Lead or 1,3-Butadiene which is known to the State of California to cause birth defects and other reproductive harm. For more information go to www.P65Warnings.ca.gov.

B01_Cat2550.indd, ddp, 04/19



General		
Size		DIN NG6 / CETOP 3 / NFPA D03
Interface		Subplate mounting according to ISO 6264
Mounting Position		as desired, horizontal mounting preferred
Ambient Temperature	[°C]	-20...+60; (-4°F ... +140°F)
MTTF _D value	[years]	75
Vibration Strength	[g]	10 sinus 5...2000 Hz acc. to IEC 68-2-6 30 noise 20...2000 Hz acc. to IEC 68-2-36 15 shock acc. to IEC 68-2-27
Hydraulic		
Maximum Operating Pressure		Ports A and P 350 Bar (5075 PSI), Port T 30 Bar (435 PSI)
Pressure Range		50 Bar (725 PSI), 105 Bar (1523 PSI), 175 Bar (2538 PSI), 210 Bar (3045 PSI), 250 Bar (3625 PSI), 350 (5075 PSI)
Nominal Flow		See p/Q curves
Fluid		Hydraulic oil according to DIN 51524...51535, other on request
Viscosity		
Recommended	[cSt] / [mm ² /s]	30 ... 80 (139 ... 371 SSU)
Permitted	[cSt] / [mm ² /s]	12 ... 38 (56 ... 1761 SSU)
Fluid Temperature	[°C]	-20 ... +60; (-4°F ... +140°F)
Filtration		ISO 4406 (1999), 18/16/13 (acc. NAS 1638: 7)
Linearity	[%]	See curve
Repeatability	[%]	<±1
Hysteresis	[%]	±1.5 of p _{max}
Electrical		
Duty Ratio	[%]	100 ED; CAUTION: Coil temperature up to 150°C (302°F) possible
Supply Voltage	[VDC]	18...30, ripple < 5% eff., surge free
Current Consumption Maximum	[A]	2.0
Pre-fusing	[A]	2.5 medium lag
Potentiometer Supply	[V]	+10 / ±5% max. 10mA
Command Signal	[V]	0...+10, ripple < 0.01 % eff., surge free, Ri = 100 kOhm
Code F Voltage	[mA]	4...20, ripple < 0.01 % eff., surge free, Ri = 200 Ohm
Code R Current		< 3.6 mA = enable off, > 3.8 mA = enable on (acc. NAMUR NE43)
Differential Input Voltage Max.	[V]	30 for terminal D and E against PE (terminal G)
	[V]	11 for terminal D and E against 0V (terminal B)
Adjustment Ranges		
Minimum Current	[%]	0...50
Maximum Current	[%]	50...100
Ramp	[s]	0...32.5
Interface		RS 232, parametrizing connection 5pole
EMC		EN 61000-6-2, EN 61000-6-4
Central Connection		6 + PE acc. EN 175201-804
Cable Specification	[mm ²]	7 x 1.0 (AWG 18) overall braid shield
Cable Length Maximum	[m]	50 (164 ft.)

B

Command/Pressure Curve

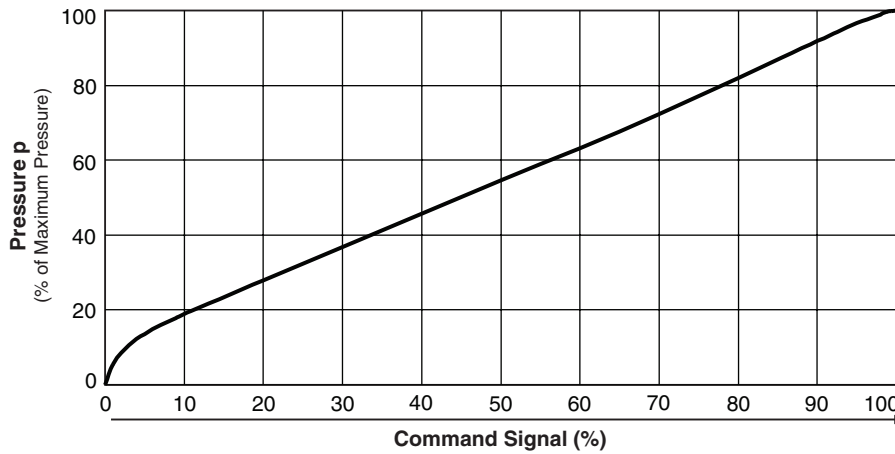

B

p_{min}/Q Curves

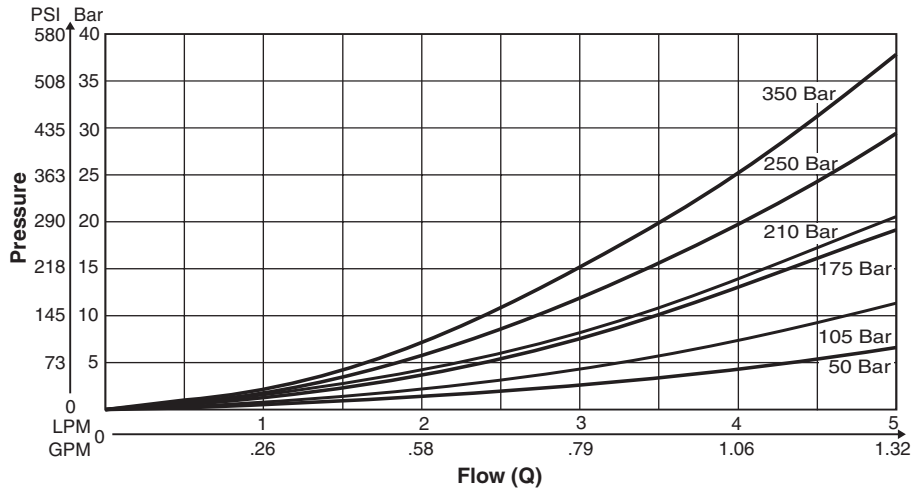

P/Q Curves

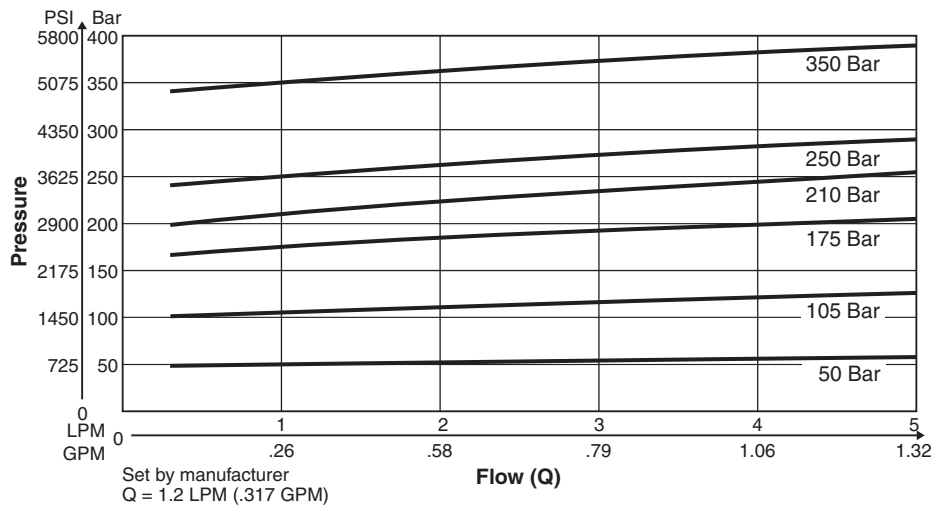

Code F
6 + PE acc. EN 175201-804

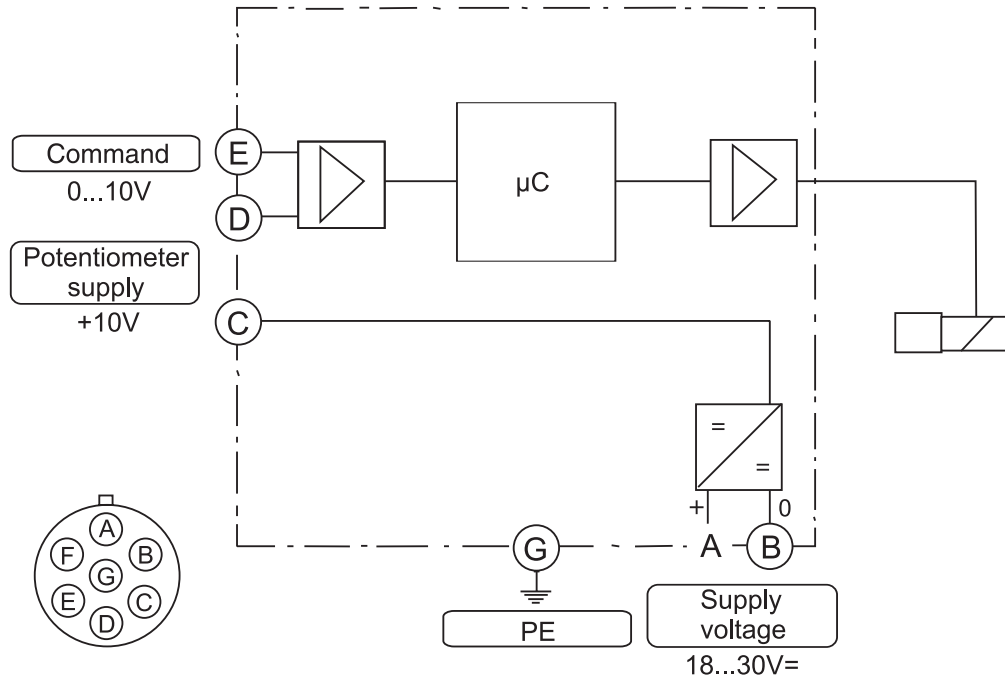

B

Code R
6 + PE acc. EN 175201-804

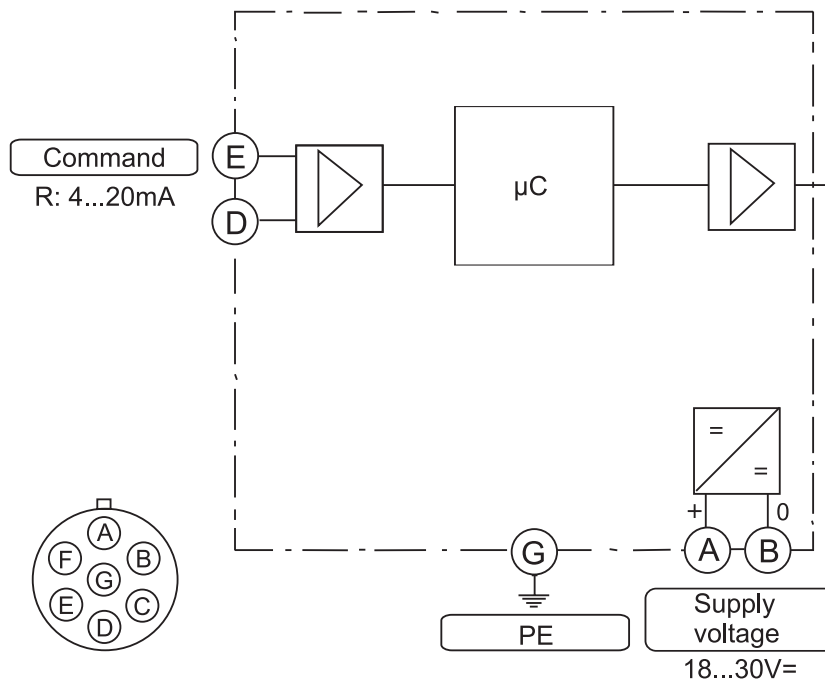

ProPxD Interface Program

The ProPxD software allows quick and easy setting of the digital valve electronics. Individual parameters as well as complete settings can be viewed, changed and saved via the comfortable user interface. Parameter sets saved in the non-volatile memory can be loaded to other valves of the same type or printed out for documentation purposes.

Features

- Simple editing of all parameters
- Storage and loading of optimized parameter adjustments
- Executable with all Windows® operating systems from Windows® 95 upwards
- Communication between PC and electronics via serial interface RS-232

The valve electronics cannot be connected to a PC with a standard USB cable – this can result in damages of PC and/or valve electronics.

Simple to use interface program. Download free of charge www.parker.com/propxd

B

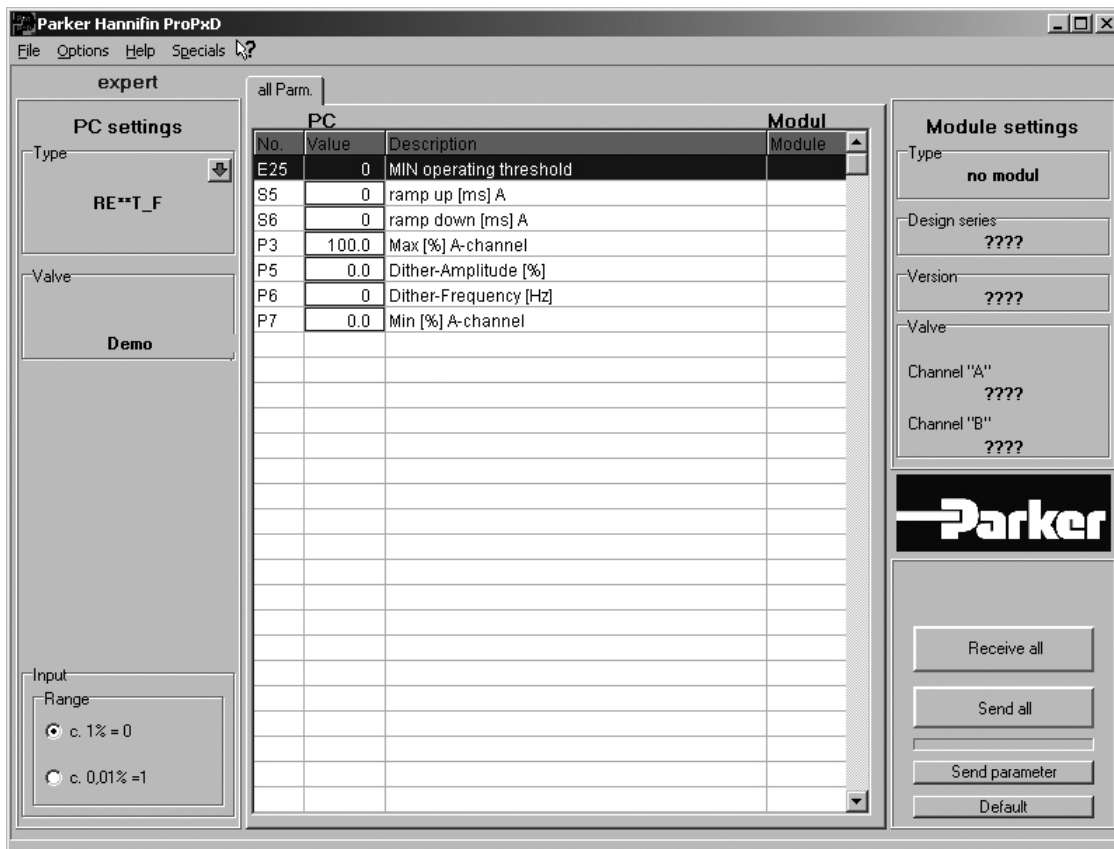

The parametrizing cable may be ordered under item no. 40982923.

Inch equivalents for millimeter dimensions are shown in (**)

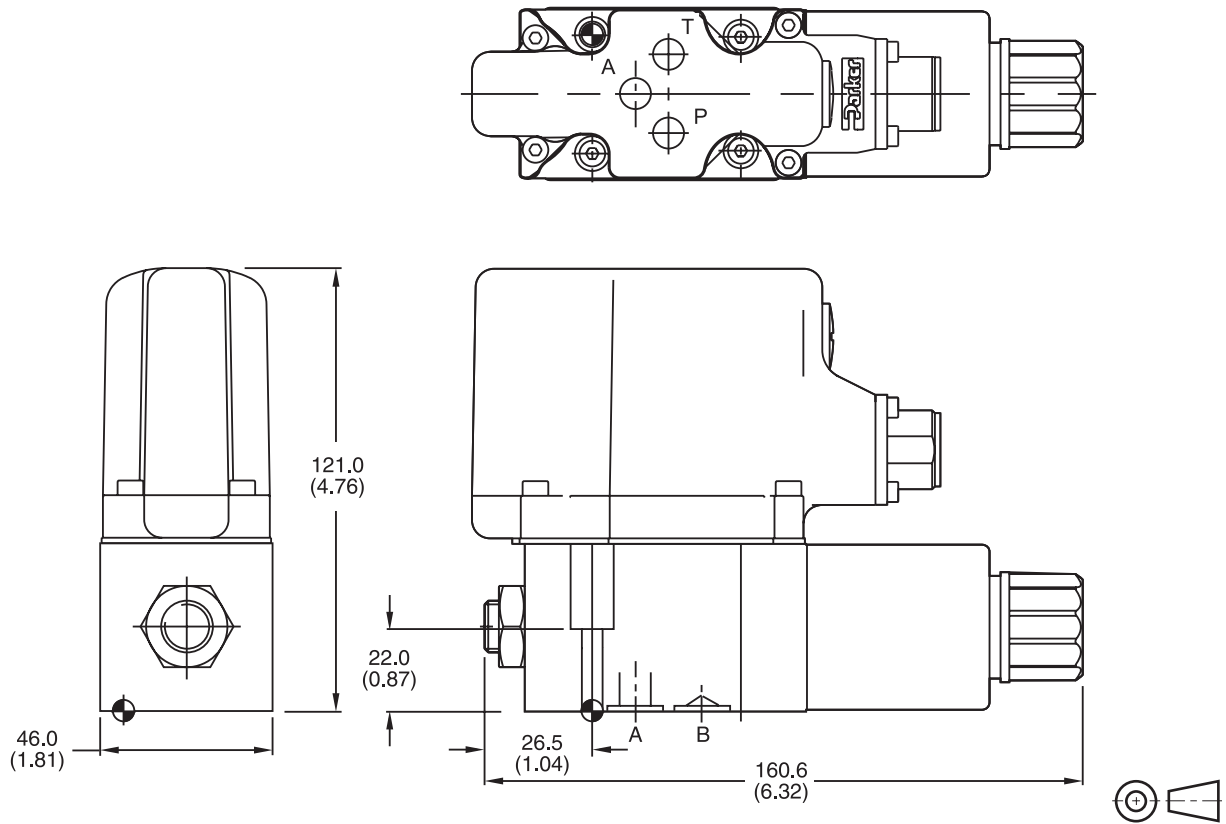

B

Surface Finish	Bolt Kit	 4x M5x30 DIN 912 12.9 4x 10-24x1.25	 7.6 Nm (5.6 lb.-ft.) ±15%	Seal Kit	
				Nitrile	Fluorocarbon
	BK375 BK209			SK-RE06MTN	SK-RE06MTV

Mounting Pattern ISO 6264-03-04-*-97

Inch equivalents for millimeter dimensions are shown in (**)

